

**A64 PRODUCT CATALOG**  
FEATURES • CONFIGURATIONS • SPECIFICATIONS





## ***Built for Mining***

The Getman A64 product range is engineered to provide a single common chassis available in configurations covering many production and production support applications, and increases value by minimizing inventory carrying costs and training requirements through its standardized design.

The A64 product line works with maximum availability to perform tasks that optimize the safety and productivity of underground mining operations, delivering materials where they need to be when they need to be there, charging explosives safely and efficiently, facilitating ground control operations in the toughest environments, and much more.

Getman A64 units not only safeguard the workers using the equipment, they redefine how tasks are performed, making underground mining operations safer and more efficient.

## ***Table of Contents***

<b><u>Purpose-Built Design</u></b>	<b>3</b>
<i>Commonality</i>	
<i>Custom Solutions</i>	
<i>Efficiency</i>	
<i>Cost and Maintenance</i>	
<i>Safety</i>	
<i>Machine Layout</i>	
<b><u>Explosives Chargers</u></b>	<b>5</b>
<i>A64 ExC 3000</i>	
<i>A64 ExC 2-500N</i>	
<i>A64 ExC 2-500</i>	
<i>A64 ExC 2-500L</i>	
<i>A64 ExC 2-500ER</i>	
<i>A64 ExC 2-1300</i>	
<b><u>Scissor Lifts</u></b>	<b>9</b>
<i>A64 SL-S</i>	
<i>A64 SL</i>	
<i>A64 SL Wing</i>	
<i>A64 SL Slider</i>	
<i>A64 SL 6M</i>	
<i>A64 SL Hanger</i>	
<b><u>Material Transporters</u></b>	<b>13</b>
<i>A64 Crane-S</i>	
<i>A64 Crane</i>	
<b><u>Service Trucks</u></b>	<b>15</b>
<i>A64 Service Lube-S</i>	
<i>A64 Service Lube</i>	
<b><u>Multi-Purpose Trucks</u></b>	<b>17</b>
<i>A64 Pallet Handler</i>	
<b><u>Additional A64 Models</u></b>	<b>19</b>
<i>A64 Personnel Carrier</i>	
<i>A64 HD Pallet Handler</i>	
<i>A64 ExC Transporter</i>	
<i>A64 Mechanics Truck</i>	
<i>A64 Boom Truck</i>	
<i>A64 Water Sprayer</i>	
<i>A64 Uphole Charger</i>	
<i>A64 Cable Stringer</i>	
<b><u>A64 Performance Data</u></b>	<b>22</b>
<i>Speed Charts</i>	

*Getman Corporation assembled this catalog with the intention of passing along the most accurate information possible, however this document shall not be binding in any way and shall be considered informational only. Getman reserves the right to make changes to the specifications herein at any time and without further notification.*



## **A64 Technical Features**

### **ENGINE**

- EPA Tier III Engine
  - › Mercedes Benz OM904LA, 129 kW (173 hp) @ 2200 rpm
  - › Cummins QSB4.5L, 127 kW (170 hp) @ 2200 rpm
- Donaldson Dry Dual-Element Air Cleaner
- Catalytic Exhaust Purifier with Muffler
- 24 V, 100 A Alternator
- 113 L (30 gal) Fuel Capacity

### **FULL REVERSING POWERSHIFT TRANSMISSION**

- Dana 32000, 3-Speed Transmission
- 4-Wheel Drive

### **AXLES AND TIRES**

- Inboard Planetary Axles with Inboard Wet Disc Brakes
  - › Standard Heavy-Duty Carraro 28.43 Axle Package
  - › Enhanced Capacity Carraro 28.60 Axle Package
- Mine Service Tires
  - › 10.00×20-16PR
  - › 12.00×20-28PR

### **INDEPENDENT BRAKING SYSTEMS**

- Service Brakes: Fully Hydraulic Wet Disc Brakes on Each Axle
- Secondary Brake: Spring Applied, Hydraulic Released Wet Disc
- Automatic Secondary Brake Application Upon Loss of Brake Accumulator Pressure, Transmission Pressure or Electrical Power

### **ORBITROL CONTROLLED, ARTICULATED STEERING**

- Heavy-Duty, Self-Aligning Bearings Inside Replaceable Inserts
- Two Double-Acting Steering Cylinders

### **HYDRAULIC SYSTEM**

- Open Center Hydraulic Circuits with Gear Hydraulic Pump
- Hydraulic Hoses Routed on Engine Cold Side

### **INSTRUMENTS AND ELECTRICAL**

- Full Instrumentation Including Engine and Transmission Gauges, Voltmeter and Hour Meter
- Instrumentation and Associated Switches Mounted in Sealed Electrical Box
- Sealed and Oil Resistant Wiring System Including Fully Sealed Connectors
- Lockable Battery Master Disconnect Switch
- LED Lighting Package

### **OPERATOR STATION**

- Three-Point Contact for Entry and Exit
- ROPS/FOPS Certified Compartment
  - › Open Canopy
  - › Enclosed Cabin with Heater, Air Conditioner and Optional Pressurizer
- Operator and Passenger Seating
- Mechanical Suspension Driver Seat

### **STANDARD EQUIPMENT**

- Audio Backup Alarm, Variable Output from 87-112 dBA
- One 2.3 kg (5 lb) Fire Extinguisher
- Ansul Fire Suppression System (Ansul LTA-101-30) Tied to Engine Shutdown
- White Epoxy Finish Paint

### **TRAMMING GRADIENTS**

- Up to 30% Max Recommended Longitudinal Gradient While Tramming (Dependent on Axles and Machine Weight)
- 9% Max Recommended Transverse Gradient While Tramming

### **WARRANTY**

- 1-Year/2,000-Hour Standard Warranty
- 5-Year/10,000-Hour Warranty on Frame and Select Structural Components



**EXC 2-500**



# Purpose-Built Design

## COMMONALITY

The A64 product range shares common components and systems across all models, a valuable feature that extends through the wide range of models available on the A64 chassis. Maintaining commonality throughout the A64 range drives value through:

- Increased safety through enhanced machine familiarity
- Minimized training requirements through use of similar hydraulic, electric and powertrain systems
- Lower inventory through shared components across all models



## CUSTOM SOLUTIONS

The A64 product range is customizable for new and specific application requirements while maintaining all of the advantages inherent in the product line. Our customer-specific solutions are driven by a proven engineer-to-order process, providing value to an A64 fleet.

## EFFICIENCY

A64 vehicles are designed exclusively for underground mining and improve efficiency by reducing the amount of workers, equipment and time required to complete everyday tasks.

## COST AND MAINTENANCE

A64 fleets reduce inventory requirements and simplify maintenance by using common components and having a consistent product layout.

- Reduced inventory requirements: Components can be specified identically across all A64 models, including axles, tires, engines, transmissions, seats and many hydraulic and electrical components
- Simplified maintenance: Utilization of common systems between models allows for efficient maintenance programs throughout the fleet

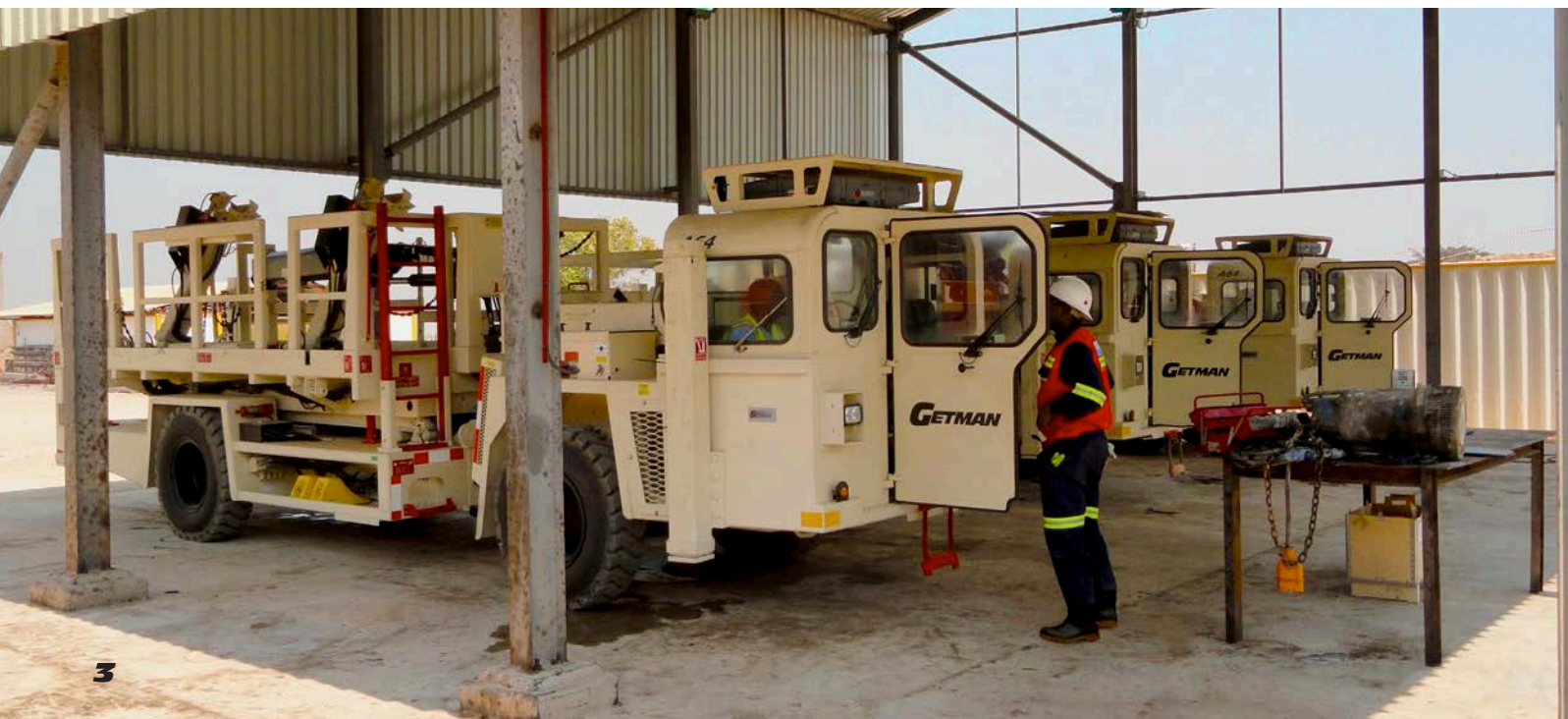

## SAFETY

Getman A64 products are focused on increasing safety in underground mining operations through purpose-built design. They provide equipment solutions engineered and built to perform everyday tasks throughout the underground mining cycle.

At Getman Corporation, designing purpose-built equipment means understanding the needs of underground mining operations, and providing safe and reliable solutions to meet those needs.

Purpose-built A64 equipment:

- Enables miners to do jobs properly in the safest and most efficient manner possible, maximizing machine and worker productivity
- Avoids improvised solutions because the equipment is designed and built for the tasks
- Reduces fall risk by providing stable, skid-proof work surfaces and fall arrest tie off points
- Decreases miner fatigue and strain-related injuries by providing mechanical lift capabilities

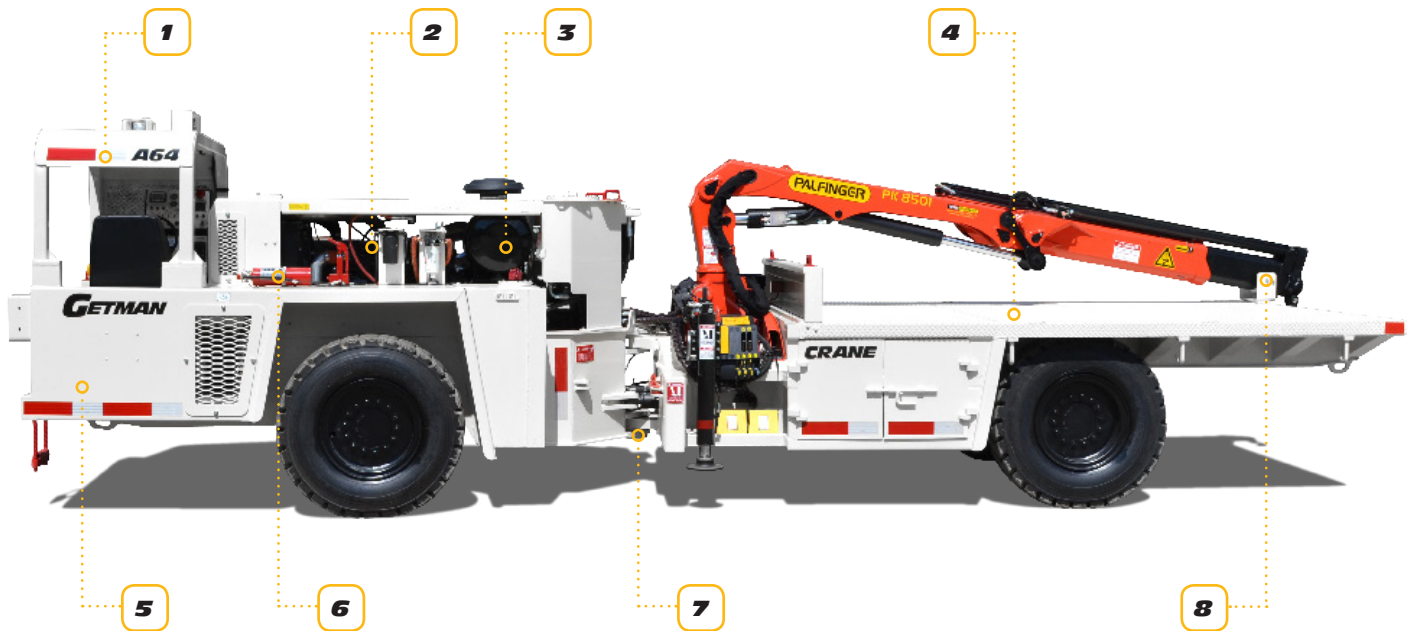

## MACHINE LAYOUT

1. ROPS/FOPS open canopy or enclosed cabin with three points of contact for entry and egress
2. Heavy-duty powertrain components to ensure the optimal combination of power, performance and reliability in underground environments
3. All daily maintenance and service performed from ground level
4. Anti-skid surfaces and fall arrest tie off points
5. Fabricated box-section frames and structural components meet the highest standards in the mining industry backed by a 5-year frame warranty
6. Ansul fire suppression system and fire extinguisher(s)
7. High ground clearance and entry/exit angles
8. Mounted equipment such as boom/basket assemblies and cranes are mounted over the frame to protect from accidental impact with walls and to reduce fatigue while tramming

# Explosives Chargers

The complete line of Getman Explosives Chargers is engineered to transport and charge explosives safely and efficiently in multiple development and production applications.

A wide range of boom configurations allow for charging multiple face sizes or in up-hole settings, and each Getman Explosives Charger can be configured to accommodate ANFO (Ammonium Nitrate and Fuel Oil) packages or emulsion packages, or both. ANFO storage tank capacity can be optimized to meet a variety of applications, and the Getman chassis accommodates most third party emulsion pumping systems.

Like all Getman A64 units, our Explosives Chargers are designed with safety as a primary consideration. Operators are protected by key features including fall arrest anchor points in the man basket. Counterbalance valves in the boom lift cylinders keep the basket from falling rapidly in the event of a damaged hose, and the ROPS/FOPS operator station canopy provides safety during tramping.



## DESIGN

- The boom and basket assembly is positioned over the chassis during tramping to reduce stresses on the boom, and to protect the boom and basket in the event of accidental contact with the mine walls
- Special corrosion-resistant hydraulic fittings are used in boom and basket assembly for improved performance when exposed to corrosive explosive materials

## EXPLOSIVES PACKAGE

- Equipped with an ANFO package and/or plug-and-play ready for a third-party emulsion package
- Multiple ANFO configurations and capacities are available, including one or two stainless steel ANFO vessels and single or dual delivery systems
- Laminated (steel/gypsum board/plywood) stick powder and cap storage compartments (30 CFR § 57.6201 Compliant)
- Equipped to charge explosives utilizing the mine's air system and/or in a self-contained version with an onboard air compressor

## MAN LIFT DEVICE

- Telescopic boom with counterbalance valves
- Self-leveling man basket
- Dual boom controls: lower controls at base of boom, upper controls (pilot hydraulic) in man basket
- Four hydraulic stabilizers with pilot check valves
- Engine start/stop and fire suppression activation controls in man basket
- Fall arrest anchor points standard on all elevated work baskets

## OPTIONS

- Air-powered electric/hydraulic package for charging explosives with the diesel engine off
- Emergency electric-powered hydraulic boom lowering package
- Safety Interlock Control System (SICS) assures stabilizers are extended before boom operation
- Hydraulic-powered hose pusher





# A64 EXC 3000

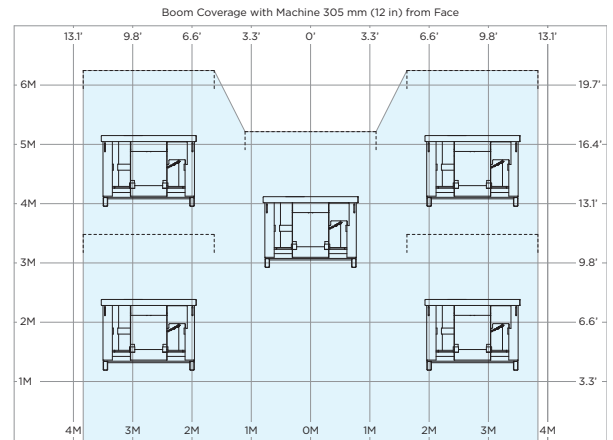
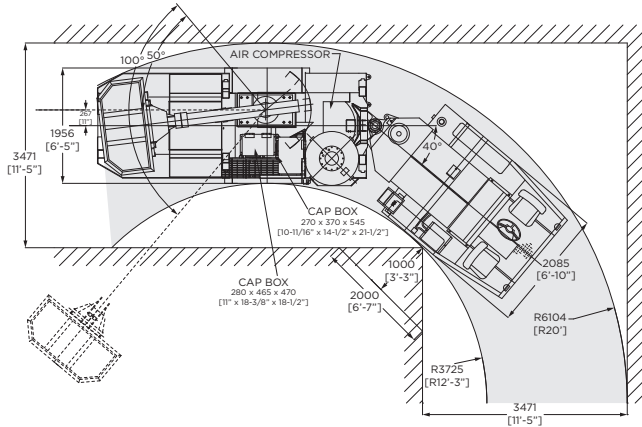
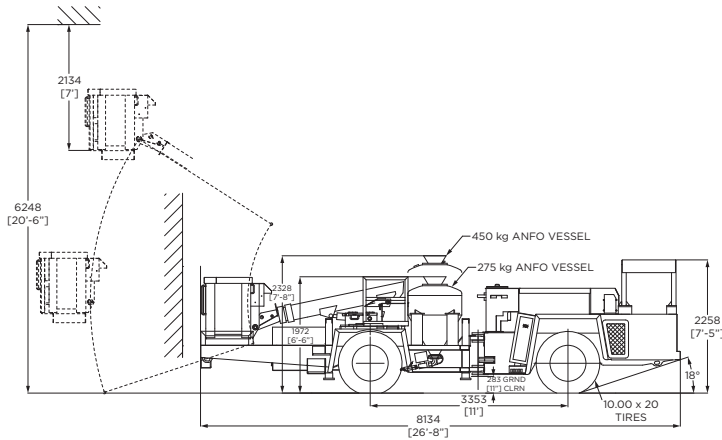

AIR SUPPLY OPTIONS	
Mine Air	✓
1.70 m <sup>3</sup> /min (60 cfm) compressor	✓
2.41 m <sup>3</sup> /min (85 cfm) compressor	✓
3.54 m <sup>3</sup> /min (125 cfm) compressor	

  

MAN BASKET CONFIGURATION	
230 kg (500 lb) basket capacity	✓
600 kg (1300 lb) basket capacity	
Rotating man basket	

EXPLOSIVES PACKAGE OPTIONS	
275 kg (600 lb) ANFO pot	✓
450 kg (1000 lb) ANFO pot	✓
900 kg (2000 lb) ANFO pot	
Two 450 kg (1000 lb) ANFO pots	
Two 900 kg (2000 lb) ANFO pots	
Emulsion-ready package	✓

Unloaded Vehicle Weight: 11,800 kg (26,000 lb)  
(Model not available in all markets)

# A64 EXC 2-500N

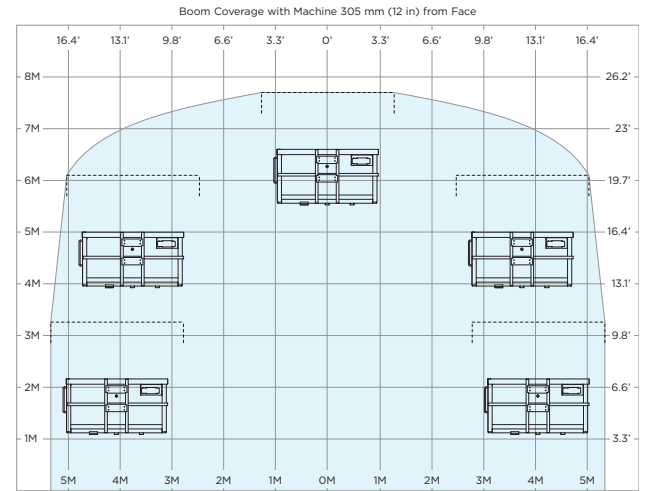
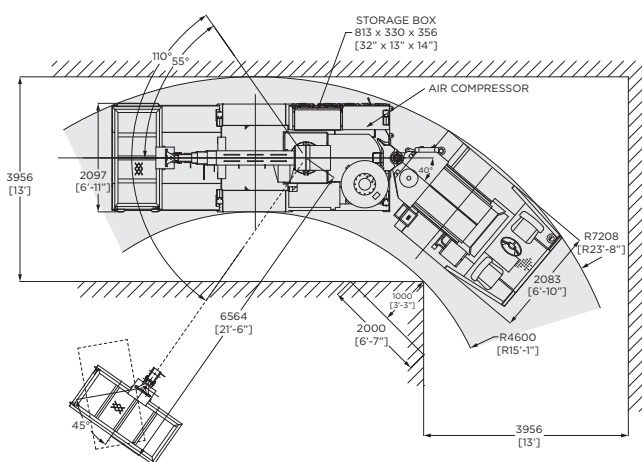
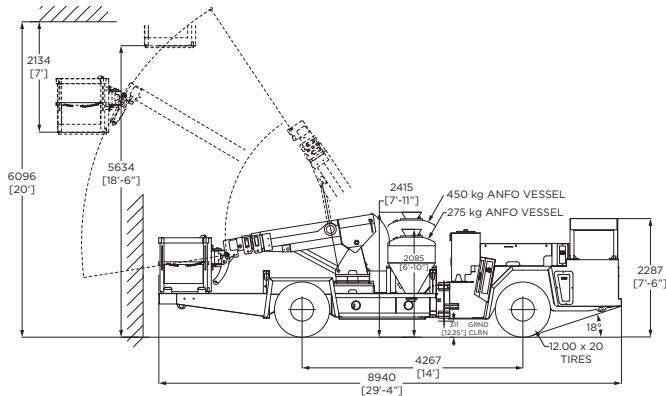

AIR SUPPLY OPTIONS	
Mine Air	✓
1.70 m <sup>3</sup> /min (60 cfm) compressor	✓
2.41 m <sup>3</sup> /min (85 cfm) compressor	✓
3.54 m <sup>3</sup> /min (125 cfm) compressor	✓

  

MAN BASKET CONFIGURATION	
230 kg (500 lb) basket capacity	✓
600 kg (1300 lb) basket capacity	
Rotating man basket	✓

EXPLOSIVES PACKAGE OPTIONS	
275 kg (600 lb) ANFO pot	✓
450 kg (1000 lb) ANFO pot	✓
900 kg (2000 lb) ANFO pot	
Two 450 kg (1000 lb) ANFO pots	✓
Two 900 kg (2000 lb) ANFO pots	
Emulsion-ready package	✓

Unloaded Vehicle Weight: 12,700 kg (28,000 lb)

# A64 EXC 2-500

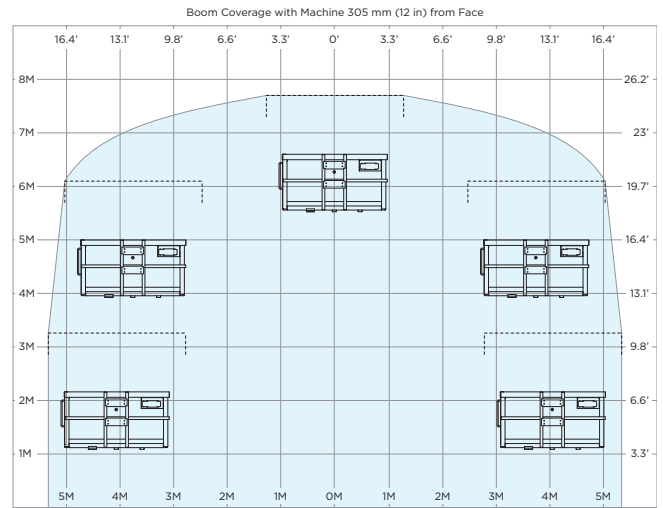
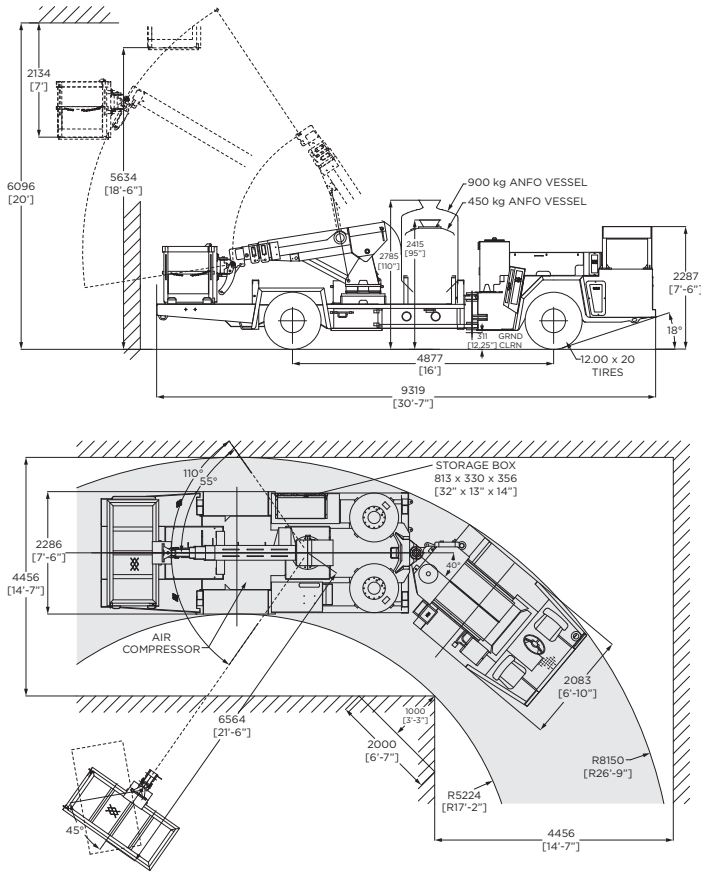

AIR SUPPLY OPTIONS	
Mine Air	✓
1.70 m <sup>3</sup> /min (60 cfm) compressor	✓
2.41 m <sup>3</sup> /min (85 cfm) compressor	✓
3.54 m <sup>3</sup> /min (125 cfm) compressor	✓

  

MAN BASKET CONFIGURATION	
230 kg (500 lb) basket capacity	✓
600 kg (1300 lb) basket capacity	
Rotating man basket	✓

EXPLOSIVES PACKAGE OPTIONS	
275 kg (600 lb) ANFO pot	✓
450 kg (1000 lb) ANFO pot	✓
900 kg (2000 lb) ANFO pot	✓
Two 450 kg (1000 lb) ANFO pots	✓
Two 900 kg (2000 lb) ANFO pots	✓
Emulsion-ready package	✓

Unloaded Vehicle Weight: 13,000 kg (28,700 lb)

# A64 EXC 2-500L

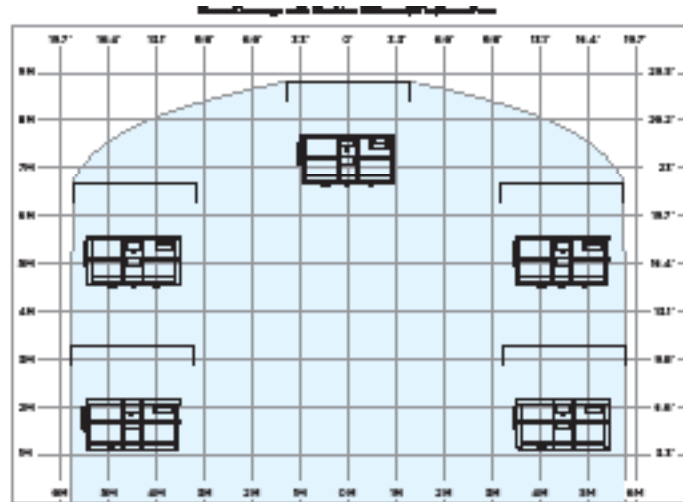
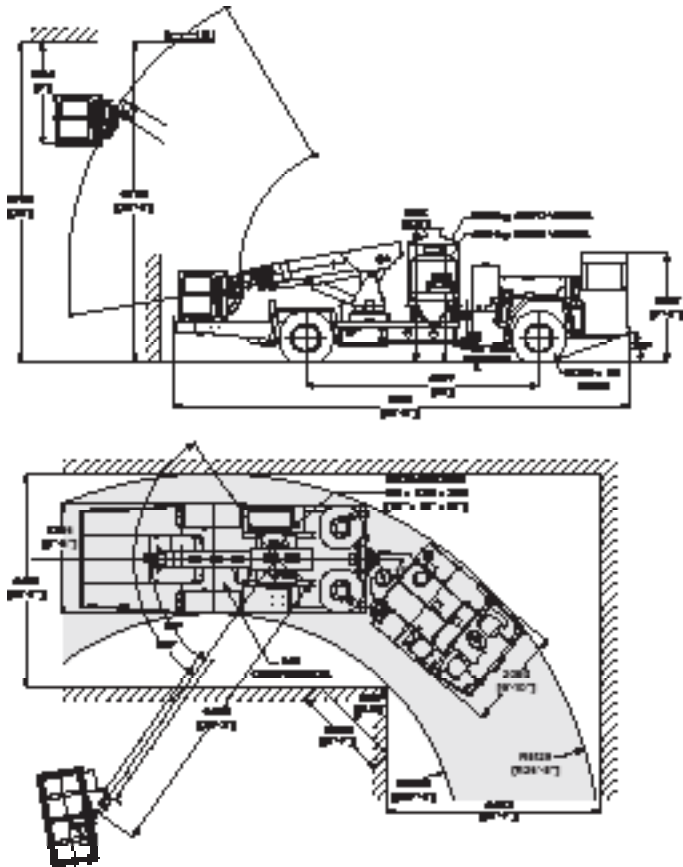

AIR SUPPLY OPTIONS	
Mine Air	✓
1.70 m <sup>3</sup> /min (60 cfm) compressor	✓
2.41 m <sup>3</sup> /min (85 cfm) compressor	✓
3.54 m <sup>3</sup> /min (125 cfm) compressor	✓

  

MAN BASKET CONFIGURATION	
230 kg (500 lb) basket capacity	✓
600 kg (1300 lb) basket capacity	
Rotating man basket	✓

EXPLOSIVES PACKAGE OPTIONS	
275 kg (600 lb) ANFO pot	✓
450 kg (1000 lb) ANFO pot	✓
900 kg (2000 lb) ANFO pot	✓
Two 450 kg (1000 lb) ANFO pots	✓
Two 900 kg (2000 lb) ANFO pots	✓
Emulsion-ready package	✓

Unloaded Vehicle Weight: 14,600 kg (32,200 lb)

# A64 EXC 2-500ER

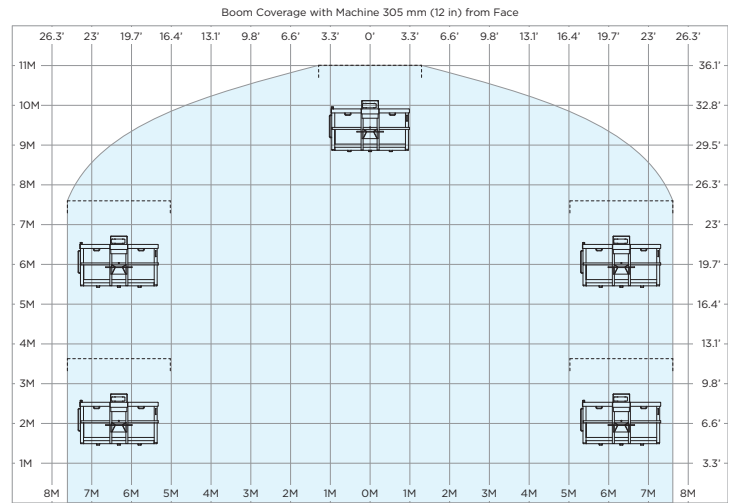
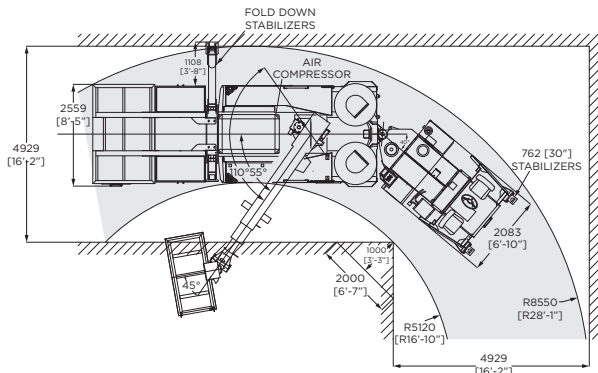
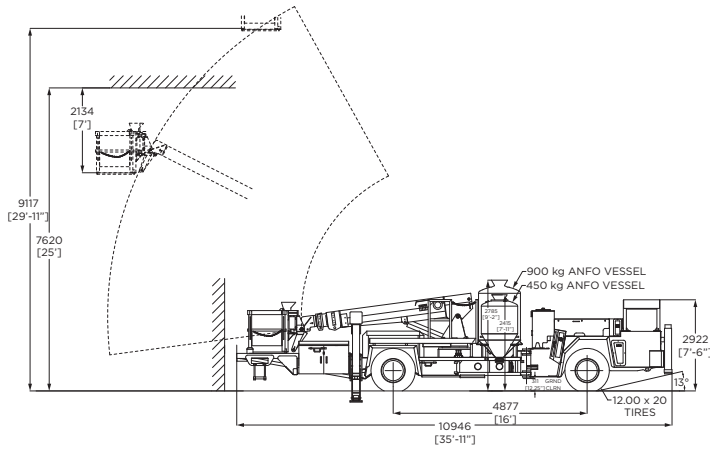

AIR SUPPLY OPTIONS	
Mine Air	
1.70 m <sup>3</sup> /min (60 cfm) compressor	✓
2.41 m <sup>3</sup> /min (85 cfm) compressor	✓
3.54 m <sup>3</sup> /min (125 cfm) compressor	✓

  

MAN BASKET CONFIGURATION	
230 kg (500 lb) basket capacity	✓
600 kg (1300 lb) basket capacity	✓
Rotating man basket	✓

EXPLOSIVES PACKAGE OPTIONS	
275 kg (600 lb) ANFO pot	✓
450 kg (1000 lb) ANFO pot	✓
900 kg (2000 lb) ANFO pot	✓
Two 450 kg (1000 lb) ANFO pots	✓
Two 900 kg (2000 lb) ANFO pots	✓
Emulsion-ready package	✓

Unloaded Vehicle Weight: 15,900 kg (35,000 lb)

# A64 EXC 2-1300

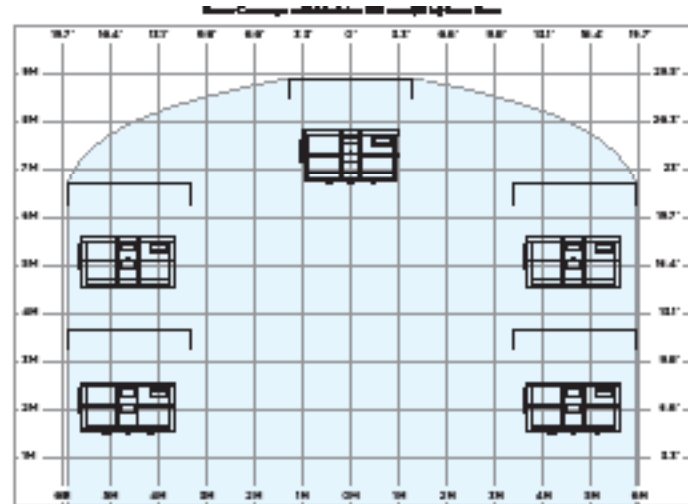
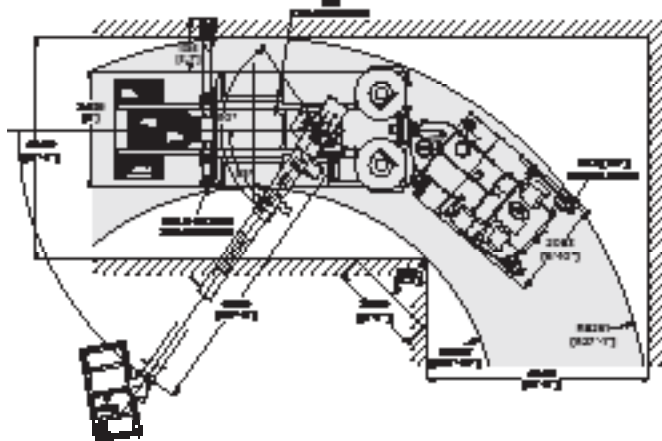
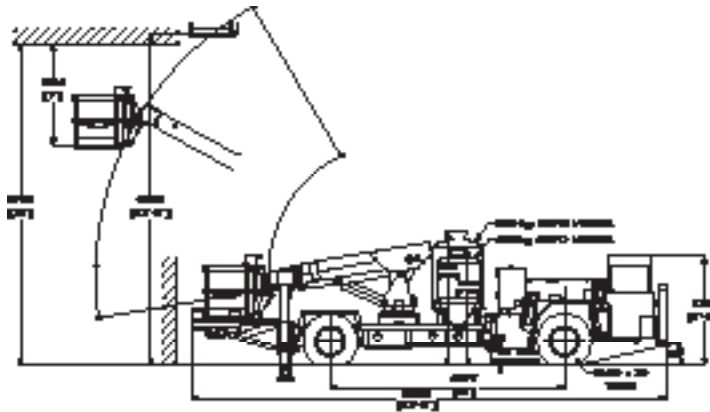

AIR SUPPLY OPTIONS	
Mine Air	
1.70 m <sup>3</sup> /min (60 cfm) compressor	✓
2.41 m <sup>3</sup> /min (85 cfm) compressor	✓
3.54 m <sup>3</sup> /min (125 cfm) compressor	✓

MAN BASKET CONFIGURATION	
230 kg (500 lb) basket capacity	
600 kg (1300 lb) basket capacity	✓
Rotating man basket	✓

EXPLOSIVES PACKAGE OPTIONS	
275 kg (600 lb) ANFO pot	✓
450 kg (1000 lb) ANFO pot	✓
900 kg (2000 lb) ANFO pot	✓
Two 450 kg (1000 lb) ANFO pots	✓
Two 900 kg (2000 lb) ANFO pots	✓
Emulsion-ready package	✓

Unloaded Vehicle Weight: 15,650 kg (34,500 lb)

# Scissor Lifts

The Getman line of mobile elevated platform trucks delivers a safe, reliable and productive range of vehicles for use in a wide assortment of maintenance and construction operations including: roof-bolting; screening and surveying; cable, pipe, and vent hanging; and many other back and rib projects.

Built on the A64 Chassis, Getman offers six variations on the Scissor Lift designed to meet the specific needs of your underground operation. Each utilizes common components and systems with the entire A64 range of production and production support equipment.

Safety in the Getman Scissor Lift range is emphasized by fall arrest anchor points located through the non-skid platform, while all Getman scissor lift trucks are thoroughly reviewed to ensure maximum stability during working operations.



## DESIGN

- Compliant with all recognized standards for stability
- Dual controls: lower controls on the rear frame, upper controls (pilot hydraulic) on platform deck
  - › Optional electric platform and stabilizer controls located in the operator station
- Engine start/stop and fire suppression activation controls located on the platform
- Four 610 mm (24 in) stabilizers standard on most models
  - › Optional four 1220 mm (48 in) leveling jacks to level the platform when working on ramps
- Telescopic ladder available on most models allowing maximum operational flexibility for work crews

## SCISSOR LIFT FEATURES

- Non-skid platform with capacities up to 3,600 kg (8,000 lb)
- Two 3-stage, single-acting cylinders with in-line flow limiters to prevent uncontrolled descent in the event of hose failure or damaged hose
  - › Optional counterbalance valves on lift cylinders (replacing in-line flow limiters) with emergency platform lowering pump-off package
- Fixed safety railing with mid-rail or safety chain
- Fall arrest tie-offs standard on all elevated work platforms

## OPTIONS

- Air powered electric/hydraulic system (using mine air while diesel engine not operating)
- Manual pipe jacks
- Safety Interlock Control System (SICS) assuring stabilizers are extended before platform operation

## PLATFORM CAPACITIES

	Standard Lift Arms 28.43 Axles	HD Lift Arms 28.43 Axles	HD Lift Arms 28.60 Axles
A64 SL-S	2,500 kg (5,500 lb)	2,700 kg (6,000 lb)	
A64 SL	2,500 kg (5,500 lb)	2,700 kg (6,000 lb)	2,700 kg (6,000 lb)
A64 SL Wing		2,040 kg (4,500 lb)	2,700 kg (6,000 lb)
A64 SL Slider		2,040 kg (4,500 lb)	2,700 kg (6,000 lb)
A64 SL 6M			3,600 kg (8,000 lb)
A64 SL Hanger			2,175 kg (4,800 lb)



## A64 SL-S

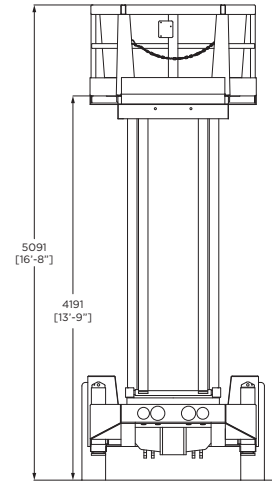
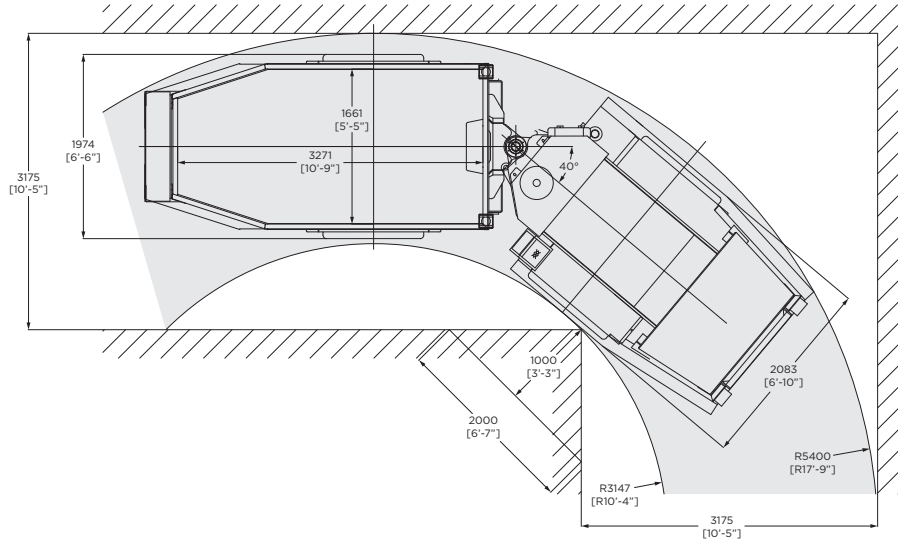
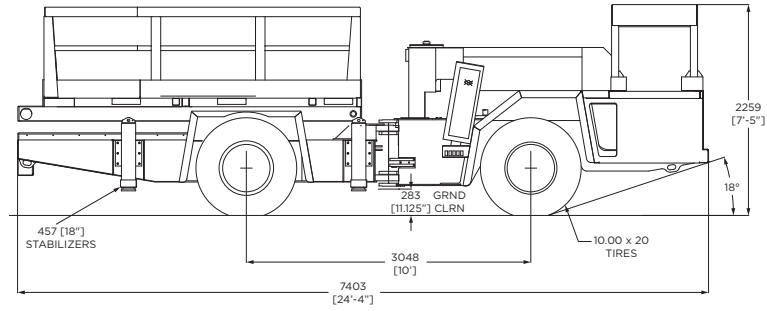

Unloaded Vehicle Weight: 10,900 kg (24,000 lb)

## A64 SL

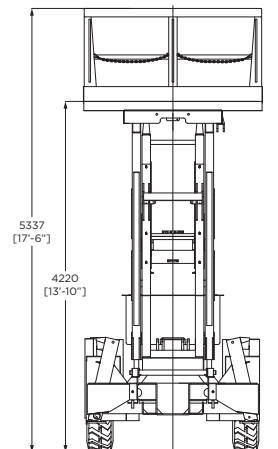
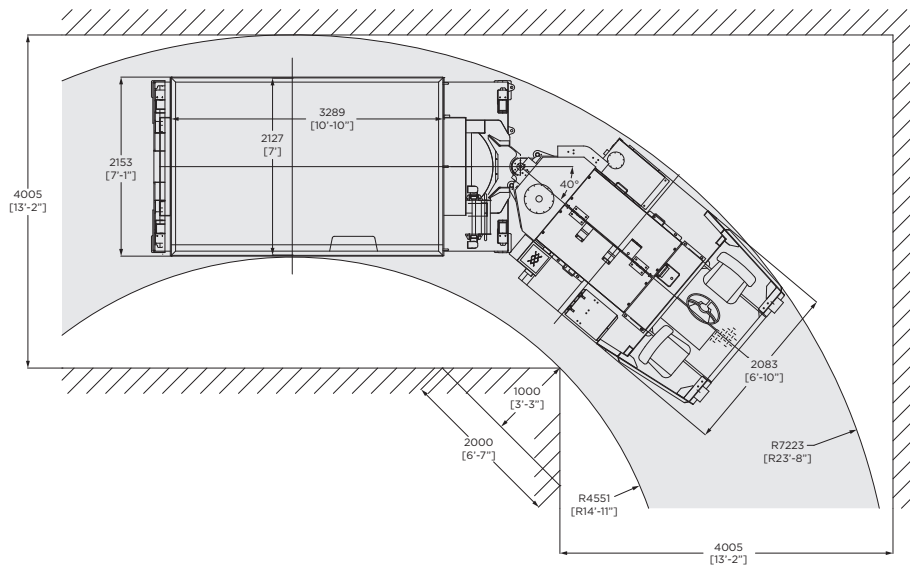
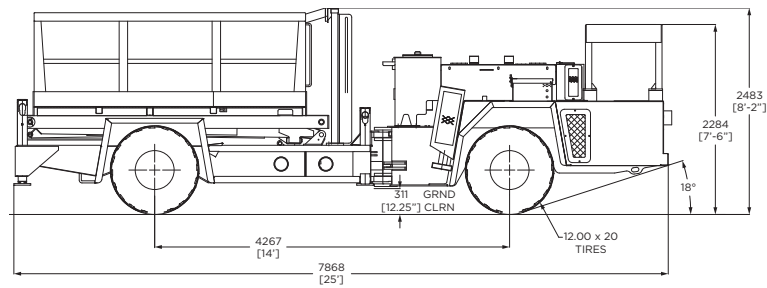

Unloaded Vehicle Weight: 12,250 kg (27,000 lb)

## A64 SL WING

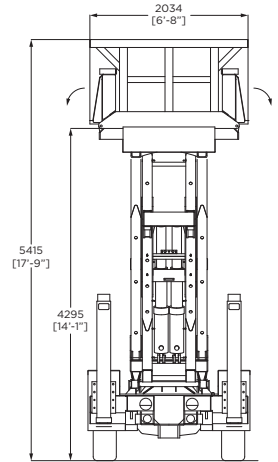
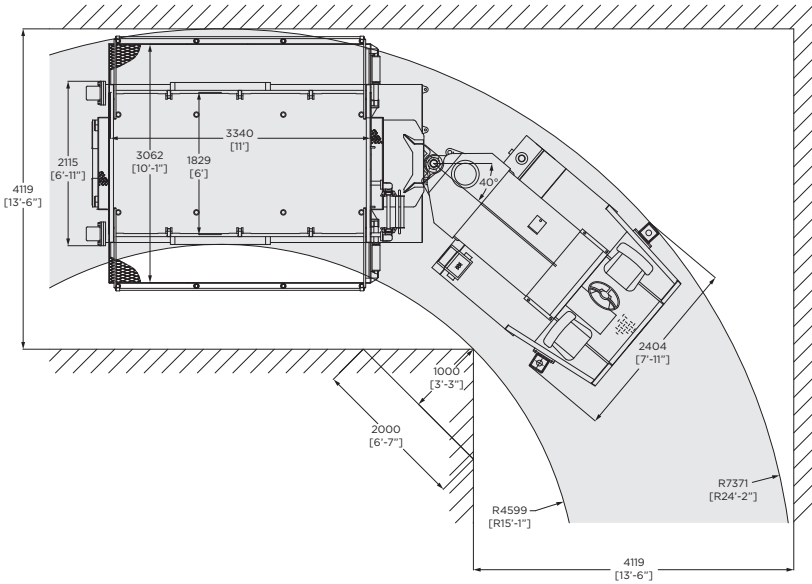
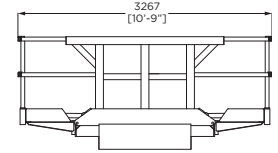
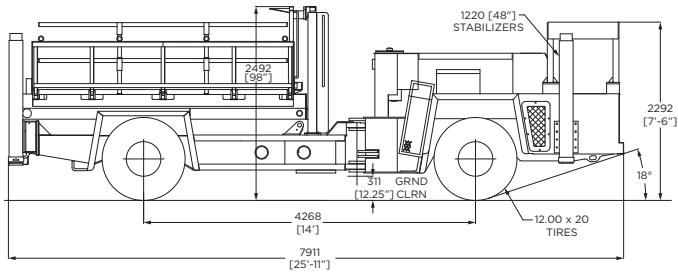

Unloaded Vehicle Weight: 12,950 kg (28,500 lb)

## A64 SL SLIDER

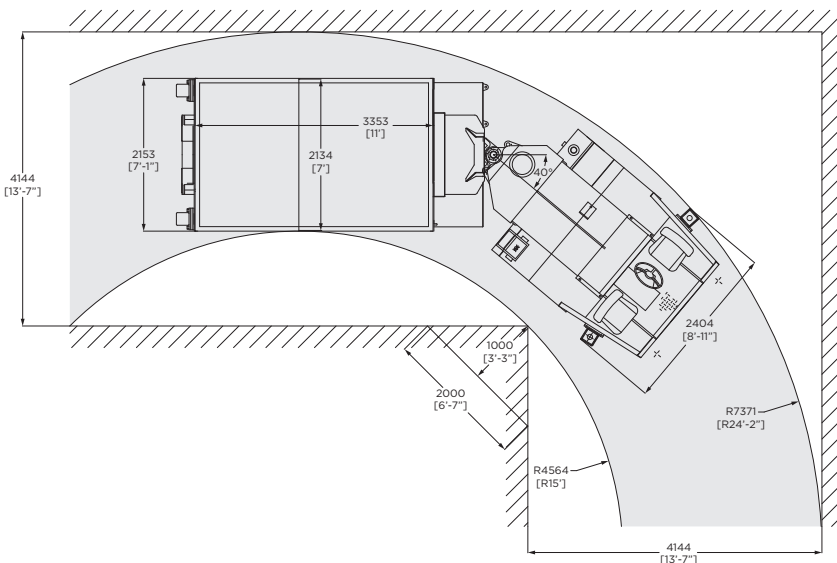
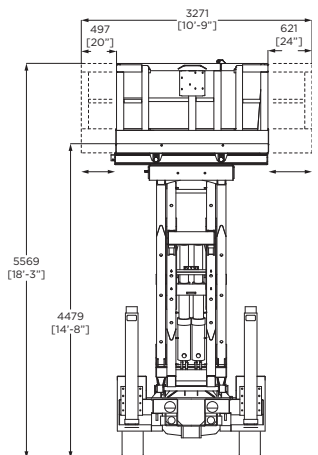
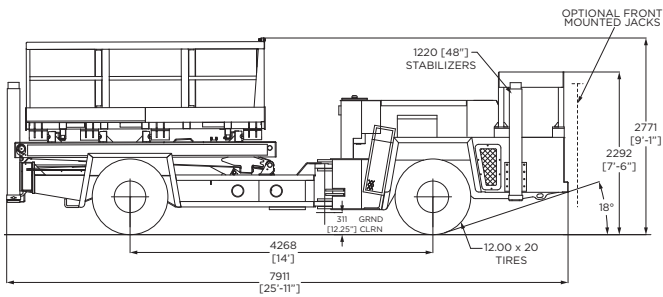

Unloaded Vehicle Weight: 13,600 kg (30,000 lb)

## A64 SL 6M

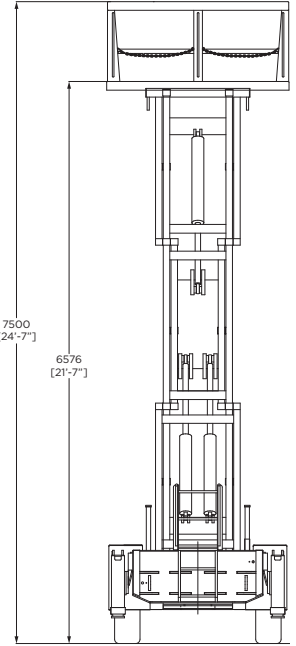
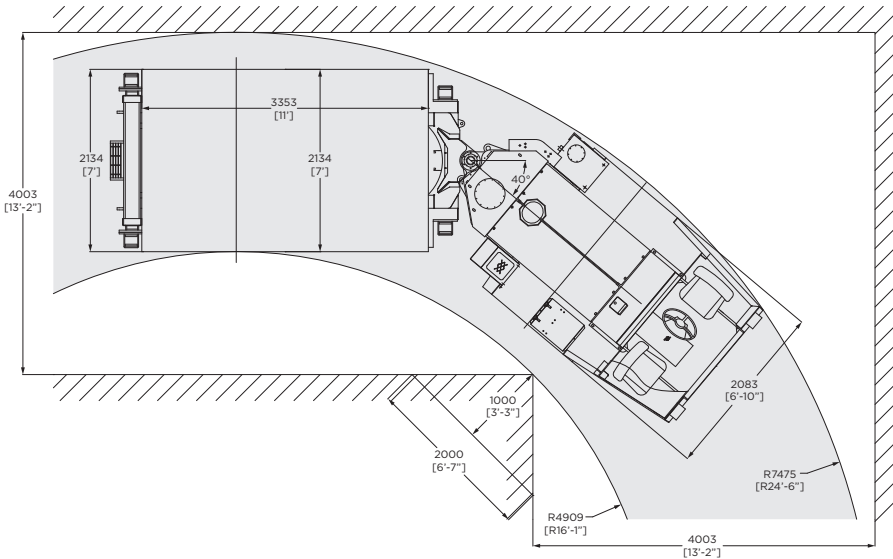
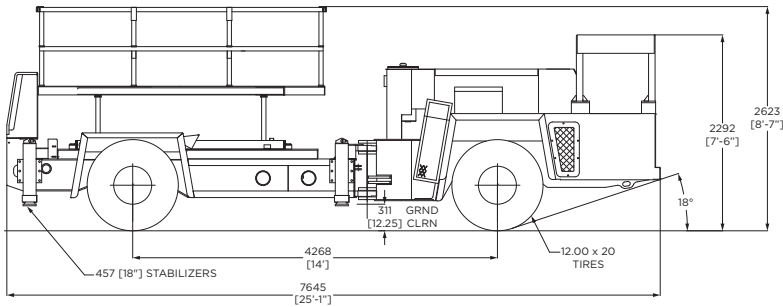

Unloaded Vehicle Weight: 15,000 kg (33,000 lb)  
(Model not available in all markets)

## A64 SL HANGER

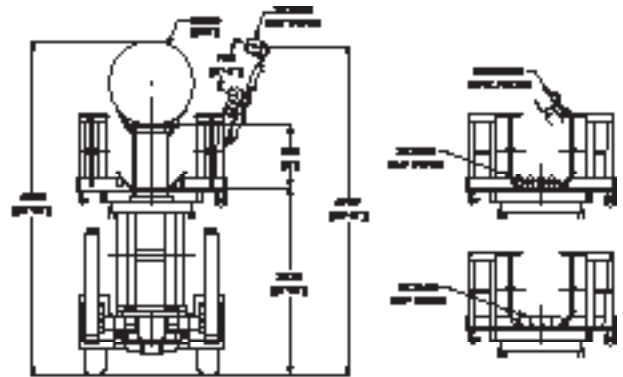
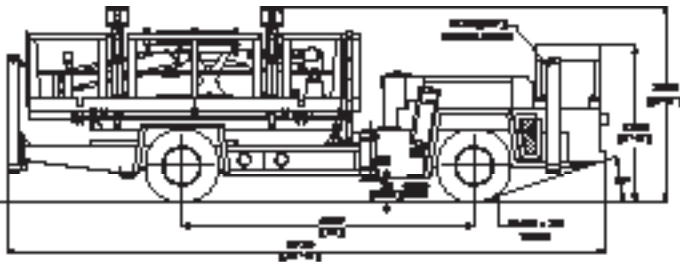

### SCISSOR LIFT FEATURES

- Deck mounted low-profile crane able to lift loads up to 1,770 kg (3,900 lb)
- Pipe jacks with grapples to handle maximum 6100 mm (20 ft) long, 200 mm (8 in) diameter, schedule 80 pipe
- Scissor mechanism flush-mounted on platform for elevating fans up to 2,180 kg (4,800 lb)

### ADDITIONAL OPTIONS

- Platform side-shifting pipe hanger model
- Heavy-duty paste-pipe installation/repair model

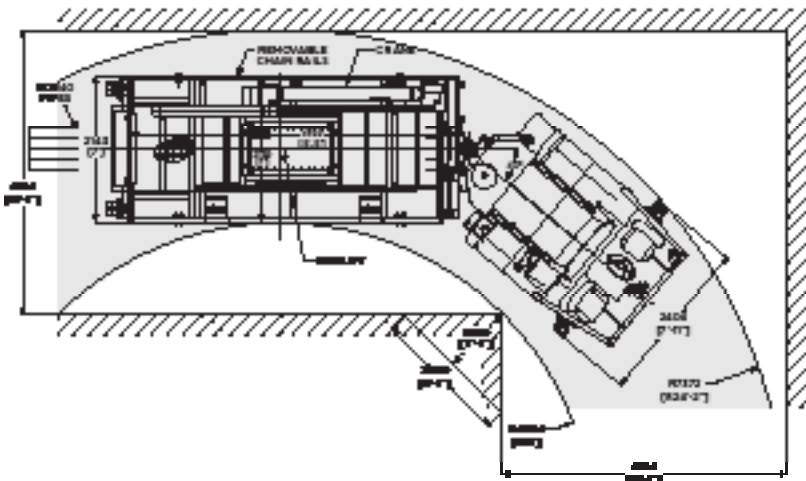

Unloaded Vehicle Weight: 15,900 kg (35,000 lb)

# Material Transporters

The Getman line of knuckle crane and flat deck trucks, all built on the A64 Chassis, includes a variety of multipurpose vehicles designed to perform a wide range of maintenance and logistics functions in underground mining operations.

A64 Crane trucks enhance safety and productivity by performing heavy lifting and transport operations with a purpose-built solution, resulting in fewer accidents and injuries during the process of moving components and supplies throughout the mining operation. Getman Crane trucks also add value to mining operations by ensuring that materials are delivered throughout the mine on time, going where they are needed, and performing when they are needed.



The design of the A64 Crane truck is optimized to deliver maximum utility in a compact envelope. The high-capacity knuckle crane is mounted near the articulation joint to maximize payload and available deck space. Deck options include low flatdeck and high flushdeck allowing for a wide variety of loading scenarios.

## DESIGN

- Crane mounted at the machine articulation joint to maximize payload and available deck space
- Crane assembly mounted within frame envelope for protection from accidental contact with mine walls during tramming
- Outriggers mounted on the crane allow unrestricted crane capacity when articulated
- Available tie-down straps for securing cargo during tramming
- Additional storage compartments available under the deck

## CRANE FEATURES

### Hiab Q44-1 (A64 Crane-S)

- 2-section knuckle crane
- 39 kN•m (28,800 ft•lb) class capacity
- 4.7 m (15 ft 5 in) maximum outreach with 830 kg (1,850 lb) capacity
- 180° slewing angle

### Palfinger PK8501A (A64 Crane):

- 3-section low mast crane
- 76.5 kN•m (56,440 ft•lb) class capacity
- 7.6 m (25 ft) maximum outreach with 2,100 kg (4,629 lb) capacity
- 180° slewing angle

## DECK CONFIGURATIONS

- Low Flatdeck: Deck height 848 mm (2 ft 9 in), distance between the fenders 1251 mm (4 ft 1 in)
- High Flushdeck: Deck height 1172 mm (3 ft 10 in), mounted over fenders for a fully flat cargo area

## OPTIONS

- Crane cylinder rod guards
- All models also available without crane

## LOAD CAPACITIES

	28.43 Axles 10x20 Tires	28.43 Axles 12x20 Tires	28.60 Axles 12x20 Tires
A64 Crane-S Low Flatdeck	4,540 kg (10,000 lb)		
A64 Crane Low Flatdeck	4,540 kg (10,000 lb)	5,450 kg (12,000 lb)	8,620 kg (19,000 lb)
A64 Crane High Flushdeck		4,540 kg (10,000 lb)	7,710 kg (17,000 lb)

*(Weight must be centered laterally and longitudinally on deck)*





# A64 CRANE-S

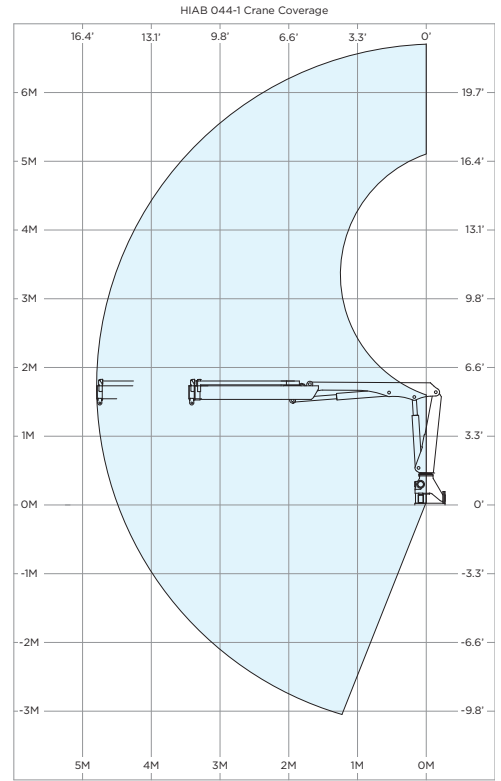
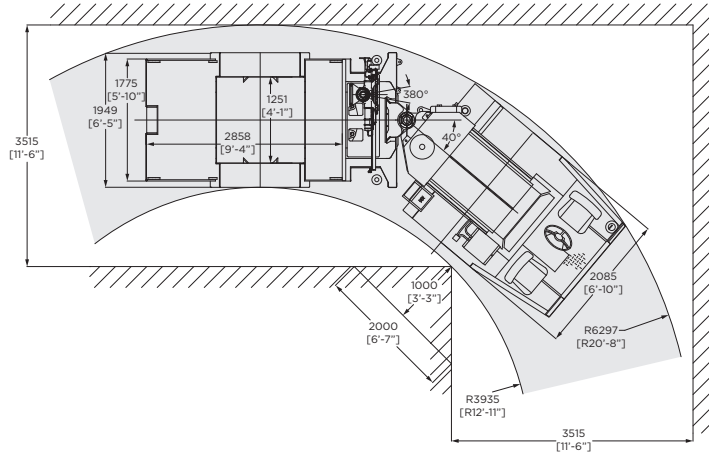
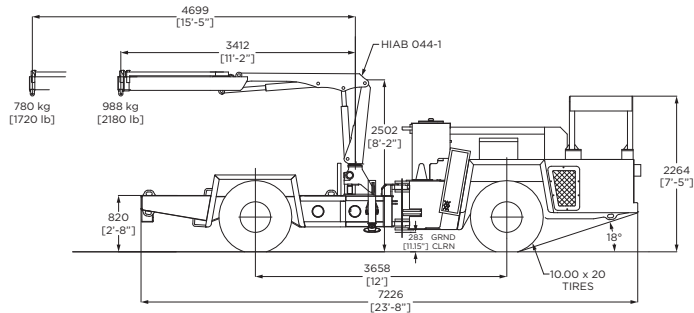

Unloaded Vehicle Weight: 8,600 kg (19,000 lb)

# A64 CRANE

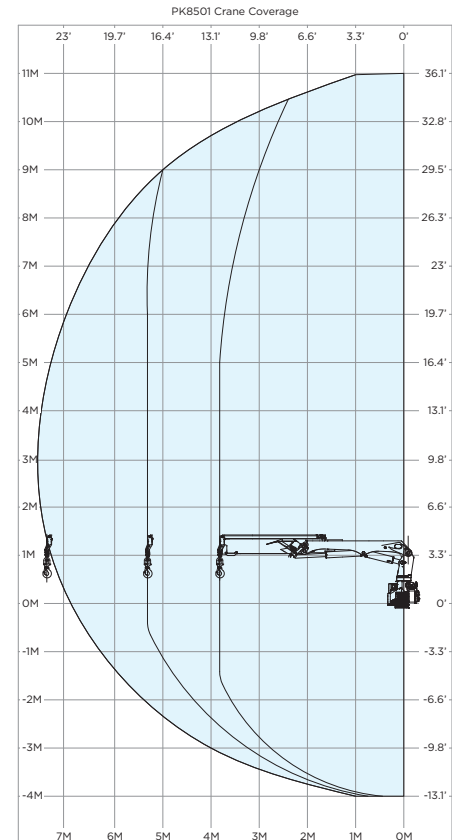
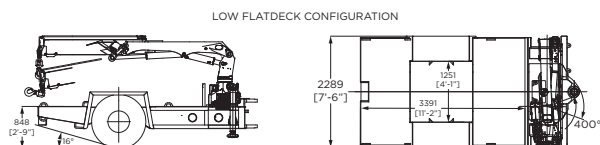
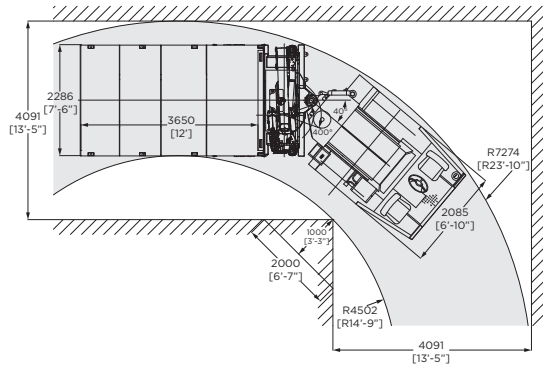
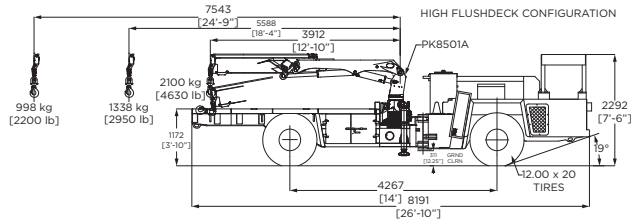

Unloaded Vehicle Weight: 11,800 kg (26,000 lb)

# Service Trucks

The Getman line of lubrication trucks is built on the A64 Chassis and is engineered to carry fuels, hydraulic oils, engine oils, drill oils and many other service fluids throughout underground mining operations. Getman Lube trucks are engineered with robust design principles allowing them to perform at high levels throughout underground mining operations with minimal downtime and maximum availability.

All Getman fuel and lubrication trucks can be customized to produce a wide variety of tank configurations, and onboard grease services and air supply are included to enhance product line utility. Individual heavy-duty, self-retracting reels for each service are designed to withstand the most demanding conditions found in underground mining while maximizing worker efficiency.

Getman Lubrication trucks also focus on protecting worker safety. Work areas are illuminated to ensure maximum visibility during operations, and auto-retract service hose reels reduce worker fatigue and strain.



## DESIGN

- Hose reels located at the rear of the machine to facilitate easy servicing on either side of the vehicle
- Service tanks located on passenger side to minimize obstructed rear visibility

## SERVICE TANK FEATURES

- Service tank construction with 6 mm (.25 in) plate and internal baffles
- Service tank fill ports located on each end of the tank for flexible operation
- Sight gauge level indicators on all service tanks
- Easy service tank clean out access for simplified maintenance
- Service tanks bolted to frame for easy removal, repair and replacement

## DELIVERY FEATURES

- Hydraulic powered fluid services with spring return hose reels
- 38 L/min (10 gpm) fluid service delivery rate with 15 m (50 ft) hose
- High-pressure, pneumatic powered grease service sized for 54 kg (120 lb) drum, including hose and reel
- Compressed air service using engine-driven compressor or higher output hydraulic-driven compressor, including air hose reel

## OPTIONS

- Increased diesel delivery rate of 190 L/min (50 gpm)
- Wiggins delivery nozzles
- Metered diesel and oil delivery nozzles
- Remote Wiggins fill for service tanks



# A64 SERVICE LUBE-S

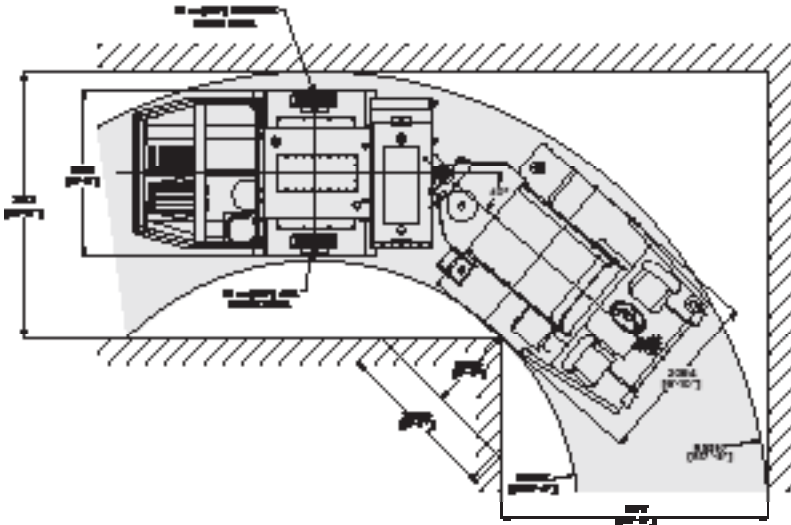
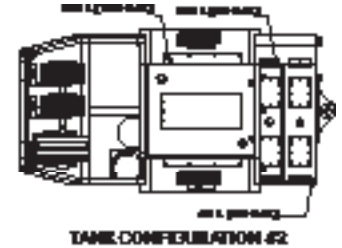
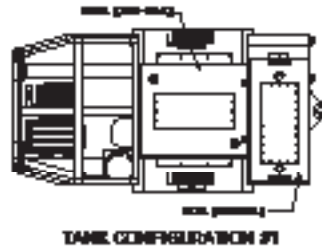
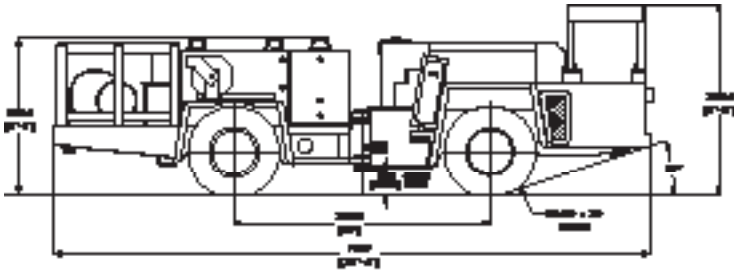

## STANDARD TANK CONFIGURATIONS

(Other tank arrangements available upon request)

	Tank 1	Tank 2	Tank 3	Tank 4	Tank 5
<b>Config #1</b>	1135 L (300 gal)	813 L (215 gal)			
<b>Config #2</b>	1135 L (300 gal)	416 L (110 gal)	302 L (80 gal)		
<b>Config #3</b>	813 L (215 gal)	568 L (150 gal)	568 L (150 gal)		

Unloaded Vehicle Weight: 9,800 kg (21,600 lb)

# A64 SERVICE LUBE

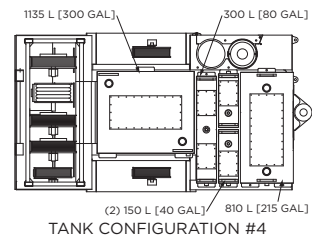
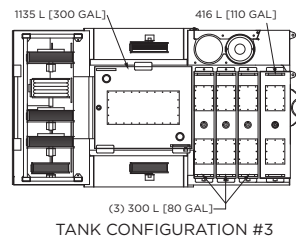
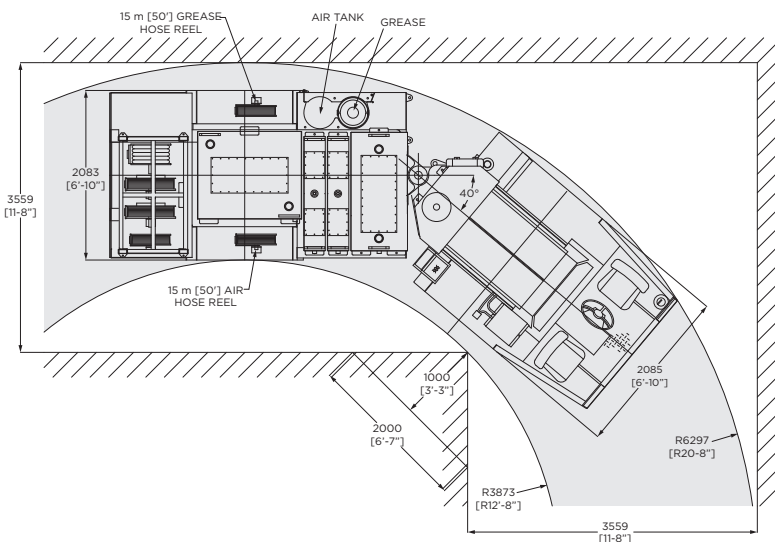
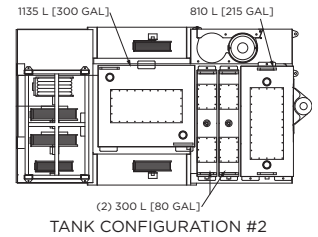
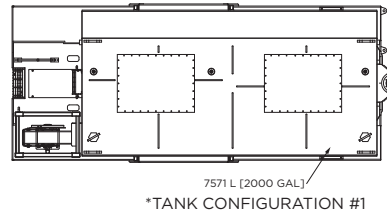
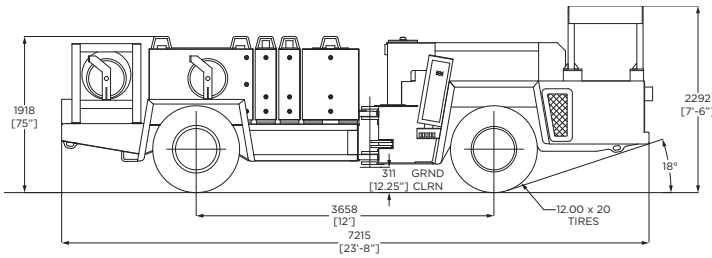

## STANDARD TANK CONFIGURATIONS

(Other tank arrangements available upon request)

	Tank 1	Tank 2	Tank 3	Tank 4	Tank 5
<b>*Config #1</b>	7571 L (2000 gal)				
<b>Config #2</b>	1135 L (300 gal)	813 L (215 gal)	302 L (80 gal)	302 L (80 gal)	
<b>Config #3</b>	1135 L (300 gal)	530 L (140 gal)	302 L (80 gal)	302 L (80 gal)	302 L (80 gal)
<b>Config #4</b>	1135 L (300 gal)	813 L (215 gal)	302 L (80 gal)	151 L (40 gal)	151 L (40 gal)

\*Machine length and turning radius will be affected with Configuration #1

Unloaded Vehicle Weight: 11,450 kg (25,000 lb)

# Multi-Purpose Vehicles

The Getman A64 Pallet Handler is a single carrier system designed to perform multiple logistics-related tasks throughout underground mining operations by utilizing application-specific pallets including: personnel carrier pallets, lubrication pallets, material transporter pallets and more.

Getman Pallet Handler systems allow mines to perform multiple part-time applications with a single carrier, maximizing equipment utilization and return on investment. The Pallet Handler also enhances safety and productivity by allowing pallets to be loaded and unloaded from ground level while the carrier is performing other functions.

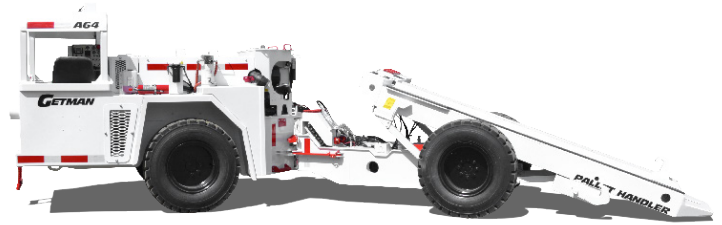

## DESIGN

- Designed for fast pick up and set down of pallets by a single operator seated in the operator's compartment
- Loading, tie-down and unloading of pallets performed at ground level
- Single control operation with indicator lights showing the stage of loading/unloading
- Easily accessed PLC control for Pallet Handler loading and unloading functions
- Roll-on/roll-off pallet loading performed using a single high-torque hydraulic motor with double roller chain and shuttle hook
- Quick couple hydraulic fittings for pallets requiring hydraulic flow

## OPTIONS

### Hiab 044-1 Crane

- 2-section knuckle crane, mounted on truck frame
- 39 kN•m (28,800 ft•lb) class capacity
- 4.7 m (15 ft 5 in) outreach
- 180° slewing angle

## PALLETS

### Flat Pallet:

- 2082 mm × 3658 mm (6 ft 10 in × 12 ft) flat deck
- 5,450 kg (12,000 lb) transport capacity on flat deck pallet

### PC Pallet:

- 16-person capacity
- Padded bench seats with individual seat belts

### Service Lube Pallet:

- Hydraulic powered fluid services with spring return hose reels
- 38 L/min (10 gpm) fluid service delivery rate with 15 m (50 ft) hose
- High-pressure, pneumatic powered grease service sized for 54 kg (120 lb) drum, including hose and reel
- Compressed air service using engine-driven compressor, including air hose reel

### Service Fuel Pallet:

- One 5300 L (1400 gal) diesel fuel tank
- 38 L/min (10 gpm) fluid service delivery rate with 15 m (50 ft) hose

### Vacuum Pallet:

- Vacuum service package
  - › 3596 L (950 gal) sump/waste
  - › 2460 L (650 gal) waste, 1135 L (300 gal) fresh chemical
- Hydraulic-driven vacuum pump

### Water Sprayer Pallet:

- One 4540 L (1200 gal) water tank



# A64 PALLET HANDLER

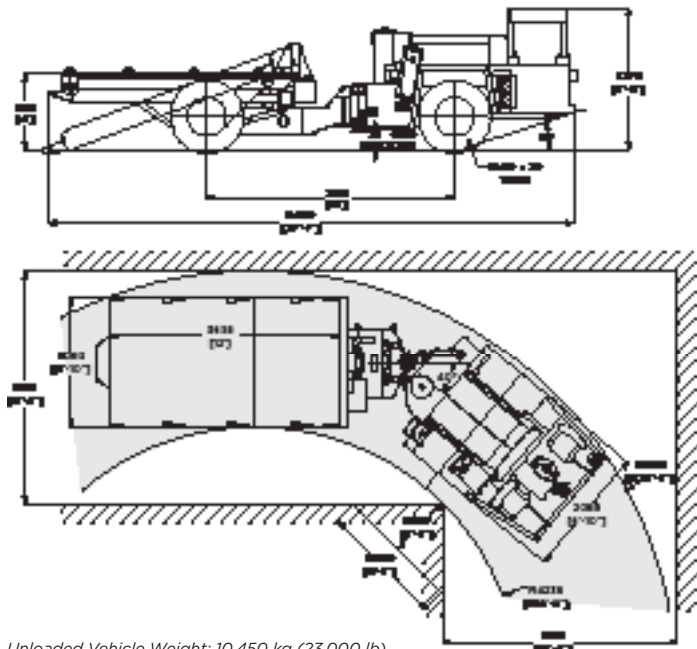

Unloaded Vehicle Weight: 10,450 kg (23,000 lb)

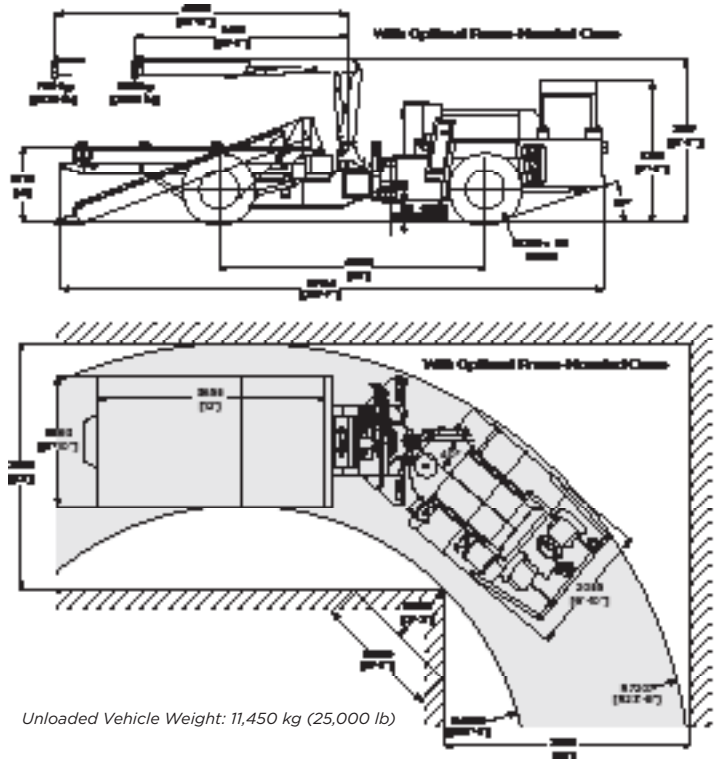

Unloaded Vehicle Weight: 11,450 kg (25,000 lb)

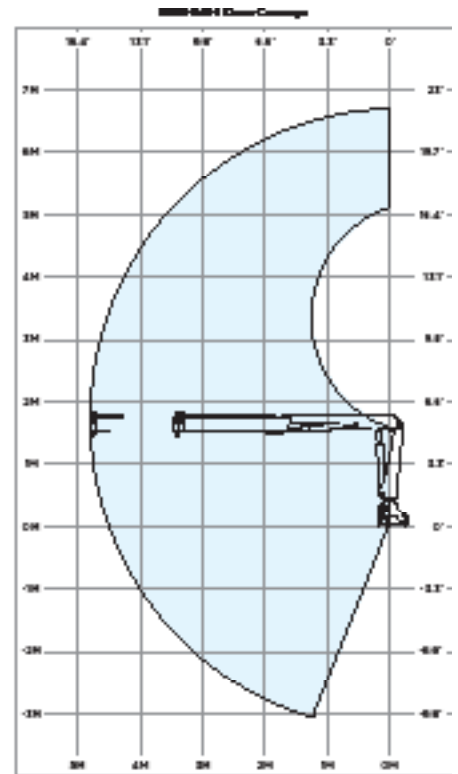
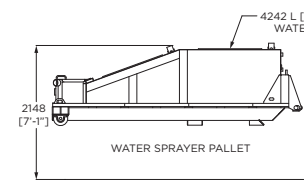
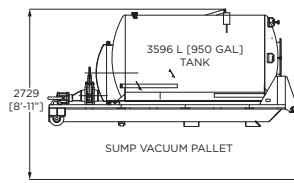
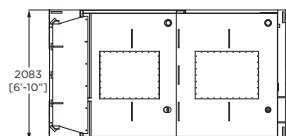
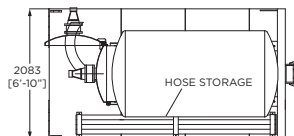
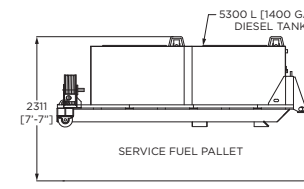
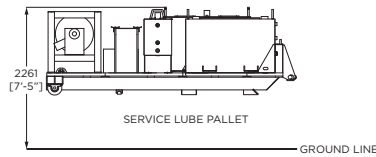
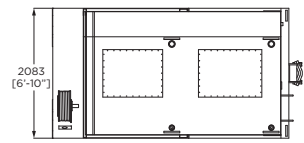
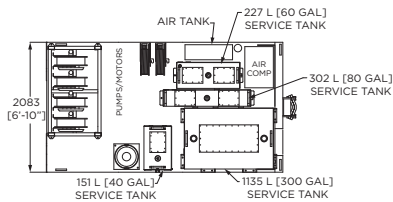
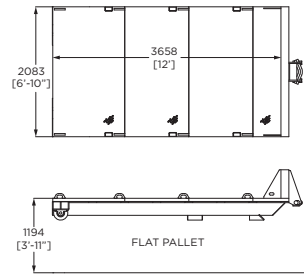
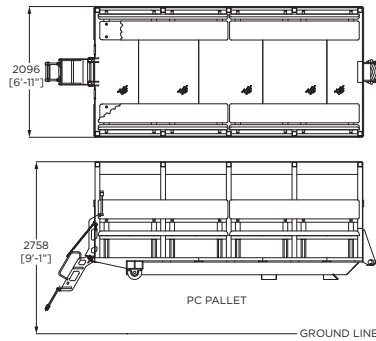

(Machine turning radius may be affected with PC Pallet loaded)

# Additional A64 Models

## A64 PERSONNEL CARRIER

Passenger capacities of 16 (pictured on right), or 23 persons with protective enclosure for personnel area, padded bench seats and individual seat belts for all passengers. Open or enclosed passenger compartments available.

### DESIGN

- Personnel capacities of 16 or 23 persons
- Padded bench seats
- Individual seat belts
- Floor mats
- Emergency operator alert buttons
- Optional individual suspension seats

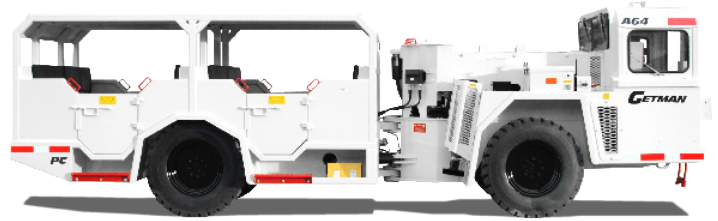

## A64 HD PALLET HANDLER

High-capacity multi-purpose vehicle capable of transporting heavy palletized loads throughout an underground operation.

### DESIGN

- 9,070 kg (20,000 lb) pallet capacity for transporting heavy loads
- Fast loading and unloading of pallets
- 2083 × 4267 mm (82 × 168 in) pallet
- Multiple application pallets available including: lubricant, fuel, vacuum, personnel carrier and more

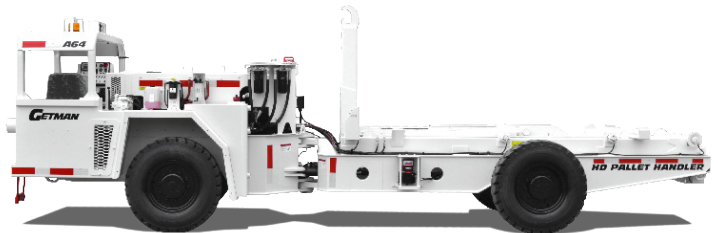

## A64 EXC TRANSPORTER

Explosives transport vehicle designed with 2,000 to 5,000 kg (4,400 to 11,000 lb) explosives capacity, and additional storage ensuring that explosives are delivered throughout the mine safely and on time.

### DESIGN

- Compact machine envelope for enhanced maneuverability between working sections
- 2,000 or 5,000 kg (4,400 or 11,000 lb) capacity
- Blasting cap and detonator storage
- All storage compartments are made with laminated walls to prevent accidental detonation from static charge



## A64 MECHANICS TRUCK

Fully customizable operational support vehicle available with knuckle crane, welder, air compressor, tool boxes, clamp vice and multiple other support tools and systems.

### DESIGN

- Multiple crane options available
- Hydraulic air compressor with reel & delivery hose
- Heavy-duty vise
- Oxy-acetylene tank storage
- Deck-mounted toolbox
- Customizable for additional mounted equipment where needed



## A64 BOOM TRUCK

Heavy-duty boom/basket utility truck with basket capacities from 225 to 590 kg (500 to 1,300 lb) and boom reaches up to 8.5 m (28 ft).

### DESIGN

- 225 to 590 kg (500 to 1,300 lb) basket capacity with fall arrest anchor points
- Full range of motion for full back coverage up to 8.5 m (28 ft)
- Compact frame layout for enhanced maneuverability
- Available with additional mounted equipment upon request



## A64 WATER SPRAYER

Heavy-duty water spray vehicle for dust suppression throughout underground operations, promoting safety through improved visibility and air quality.

### DESIGN

- 7,570 L (2,000 gal) tank capacity
- Baffled interior tank design to eliminate massive shifts of tank contents
- Four nozzle water spray system optimizing spray pattern for maximum dust suppression
- Configurable spraying system to ensure proper operation in a variety of environments



## A64 UPHOLE CHARGER

Bulk explosives loading vehicle equipped with a third-party emulsion pumping package capable of handling up to 8 tons of explosives for large-scale up-hole charging applications. Customizable to meet operational needs and configurable to work with most explosive providers' systems.

### DESIGN

- Available with or without boom and man basket
- Customizable to work with preferred emulsion supplier
- Bulk explosives loading capability with tank capacities up to 8 tons
- Optional hose pusher



\*customer installed system shown

## A64 CABLE STRINGER

Electrician's vehicle designed to install or retrieve cable safely and efficiently utilizing a boom/basket setup and a variable speed, hydraulically driven cable drum.

### DESIGN

- Cable spindles can be picked up with hydraulic arms at the rear of the truck and transported throughout the mine, or unspooled onto an onboard reel
- The boom and basket assembly is positioned over the chassis during tramming to reduce stresses on the boom, and to protect the boom and basket in the event of accidental contact with the mine walls
- Dual boom controls: lower controls at base of boom, upper controls (pilot hydraulic) in man basket
- Multiple sizes capable of installing cable in headings ranging from 3.5 × 3.5 m (11.5 ft × 11.5 ft) to 6.0 × 6.0 m (19.5 × 19.5 ft)
- Slow-tramming feature allows the machine to be repositioned with the boom extended
- Fall arrest anchor points in the man basket

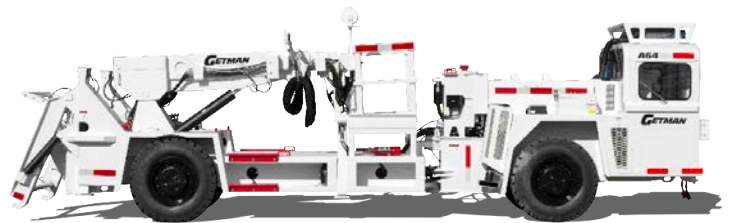



# A64 Performance Data

## Mercedes Benz OM904 Engine Package

<b>Manufacturer</b>	Mercedes
<b>Model</b>	OM904
<b>Stage</b>	Tier III
<b>Design</b>	4 Cylinders in line, water cooled
<b>Max Power</b>	129 kW (173 hp) @ 2200 rpm
<b>Exhaust System</b>	Catalytic exhaust conditioner and silencer
<b>Aspiration</b>	Turbocharged
<b>Fuel Consumption</b>	220 g/kW-hr (0.361 lb/hp-hr)

## Cummins QSB4.5 Engine Package

<b>Manufacturer</b>	Cummins
<b>Model</b>	QSB4.5
<b>Stage</b>	Tier III
<b>Design</b>	4 Cylinders in line, water cooled
<b>Max Power</b>	127 kW (170 hp) @ 2200 rpm
<b>Exhaust System</b>	Catalytic exhaust conditioner and silencer
<b>Aspiration</b>	Turbocharged
<b>Fuel Consumption</b>	243 g/kW-hr (0.399 lb/hp-hr)

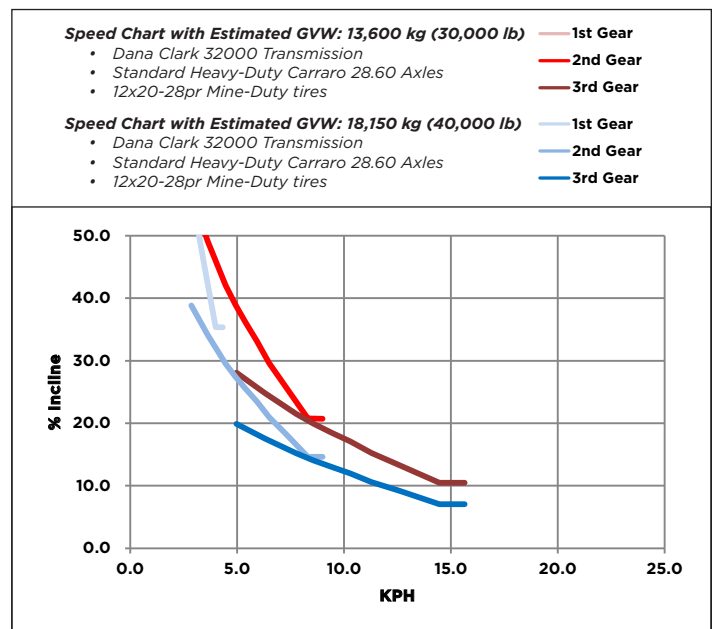
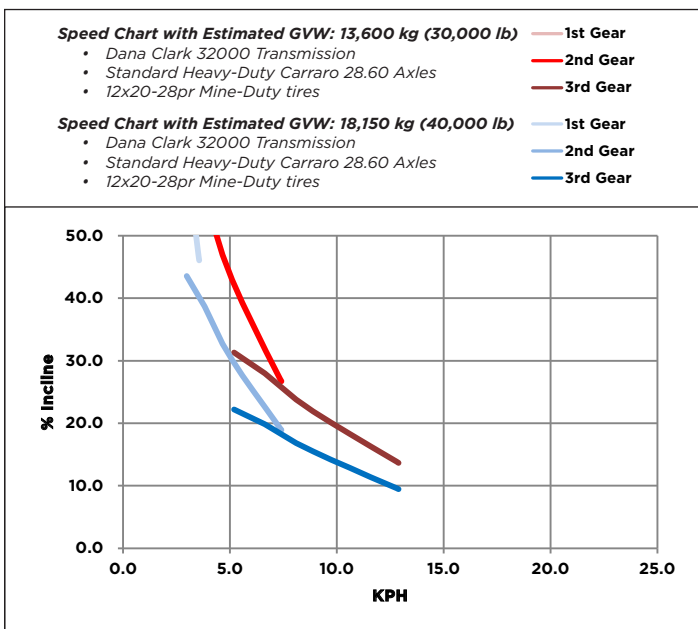
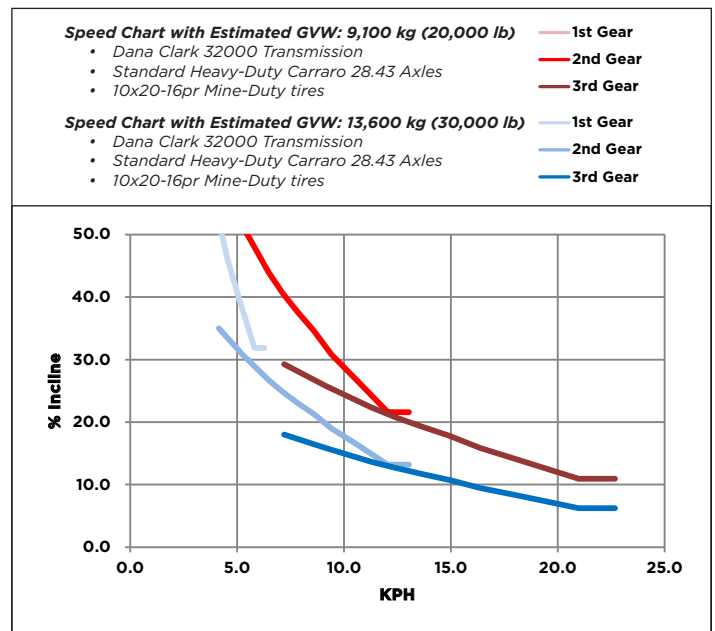
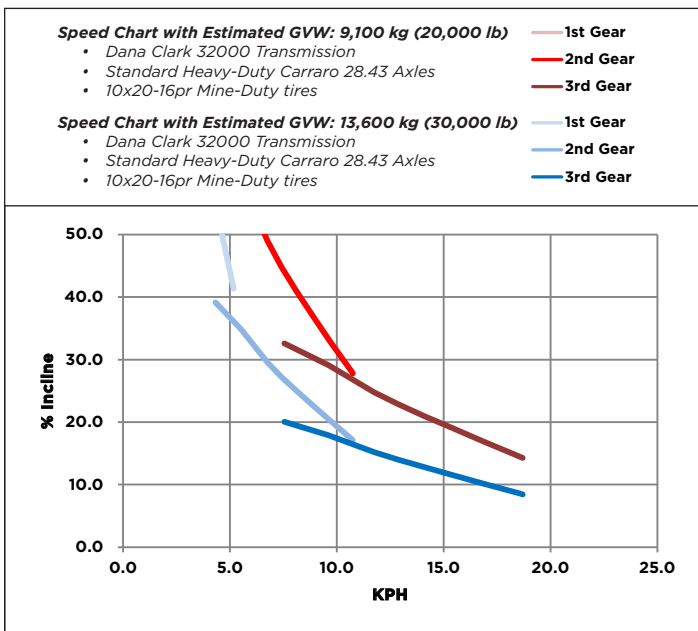



**[WWW.GETMAN.COM](http://WWW.GETMAN.COM)**



**SHOTCRETE SPRAYING  
& TRANSPORT**



**MECHANICAL SCALING**



**LOW PROFILE & COAL**

Getman Corporation  
59750 34th Avenue  
Bangor, MI 49013 USA



Tel: +1 (269) 427-5611  
Fax: +1 (269) 427-8781  
[www.getman.com](http://www.getman.com)